



All information contained herein applies only to the above listed part number. Other versions of this part number with electrical or mechanical variations are available. Contact CUI Inc. for further assistance. 9615 SW Allen Blvd., Ste. 103, Beaverton OR 97005
 800-275-4899 • 503-643-4899 • Fax: 503-643-6129 • www.cui.com

1. CONSTRUCTION:

- 1.1 Surface: Damage, rust, foam not permitted.
- 1.2 Lead pull test: _____ Kg for _____ Seconds.
- 1.3 Impregnation: Varnish.
- 1.4 Lead wire description:

Terminal No.	1	2	3	4	5	6	7	8	9	10
Color										
Length (mm)										
Strip/Tin (mm)	/ / / / / / / / / / / /									
Class										

2. ELECTRICAL CHARACTERISTICS:

- 2.1 Exciting Current: Input primary 120 v 60 Hz 40 MA MAX.
- 2.2 Primary rated voltage & frequency: 120 V 60 Hz.
- 2.3 Secondary output voltage:

Leads No.or Color	Rated Voltage	Rated Current	Voltage Regulation	No Load Voltage
3-----4	AC 9V±5%	AC 100mA		AC 10V±5%

- 2.4 HI-POT test: Input 60HZ 1500 V for one minute between Primary and Secondary and between Primary to Core. 1000 V for one minute between Secondary and Secondary and between Secondary to Core.
- 2.5 Induced Voltage: At Secondary open. input Primary 400HZ 240 V for 15 seconds.
- 2.6 Insulation test: 500Vdc 100 M Ohm Min. between Windinhs and Windings and Core.
- 2.7 Humidity test: Temp. 32 ± 2 °C relative humidity 90%RH for 6 hours, after keeping 30 minutes following insulation must be larger than 5 Megohm.
- 2.8 Temperature rise test: Less than 70 °C for rated test with Resistance method.

3. Adequate Standard:

4. Circuit Diagram:

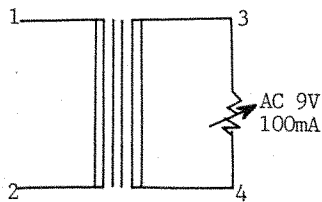

5. Dimension (mm).

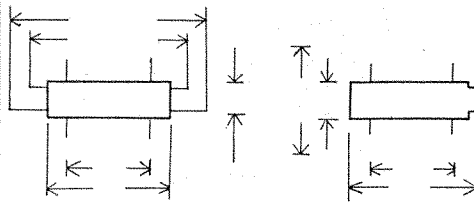



All information contained herein applies only to the above listed part number. Other versions of this part number with electrical or mechanical variations are available. Contact CUI Inc. for further assistance. 9615 SW Allen Blvd., Ste. 103, Beaverton OR 97005
800-275-4899 • 503-643-4899 • Fax: 503-643-6129 • www.cui.com

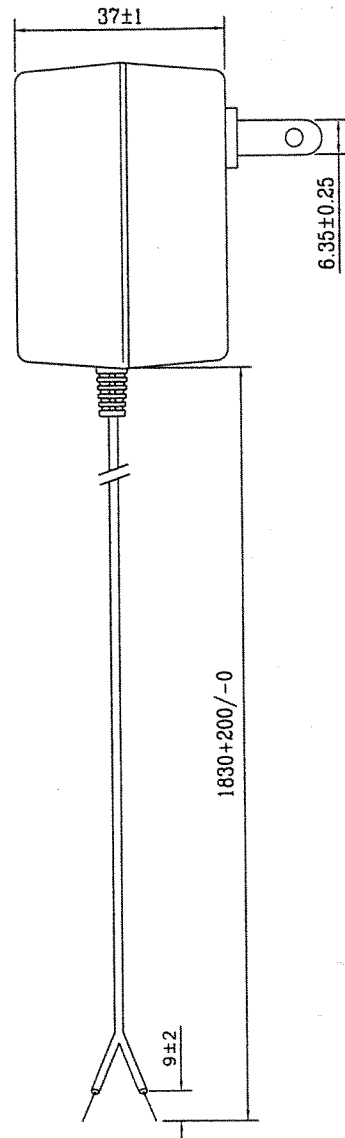
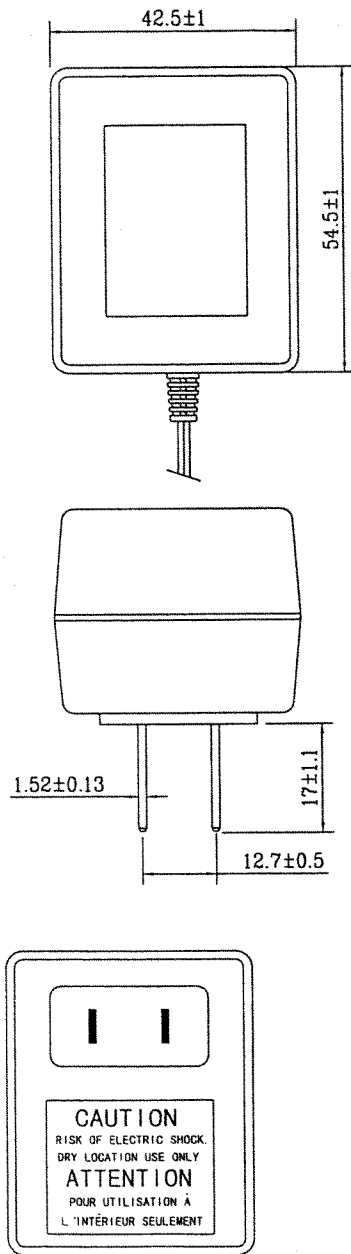



All information contained herein applies only to the above listed part number. Other versions of this part number with electrical or mechanical variations are available. Contact CUI Inc. for further assistance. 9615 SW Allen Blvd., Ste. 103, Beaverton OR 97005
800-275-4899 • 503-643-4899 • Fax: 503-643-6129 • www.cui.com

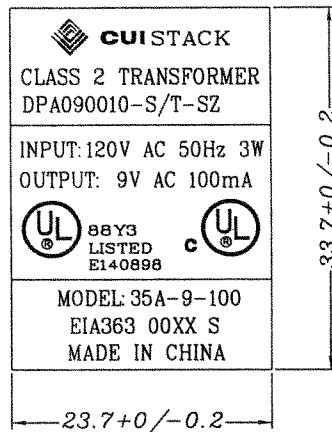

REMARKS: 00XX S

00 provides production year
 xx provides production week
 s Fu Yong

Adhesion strength of specification label (Tape peeling test)
 Firmly apply pressure sensitive adhesive tape on the middle
 of the specification label to the lengthwise direction
 Pull the tape off quickly at a 90° angle to the surface of
 the label once.

[Specification] There shall be no blistering or peeling
 of the specification label.

[Used adhesive tape] 3m #44 Tape 18 width

Thickness: 0.2mm

Material: PVC

ALUMINIUM

BLACK WORD ON SILVER BASE

SILVER WORD ON BLACK BASE

WHITE WORD ON BLACK BASE

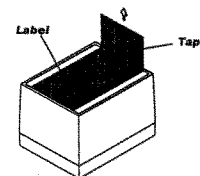

SPEC NO: SZ-9100



CUI INC

PAGE NO: 5 of 5

PART NO: DPA090010-S/T-SZ

UNIT: mm

DATE: 03/19/00

All information contained herein applies only to the above listed part number. Other versions of this part number with electrical or mechanical variations are available. Contact CUI Inc. for further assistance. 9615 SW Allen Blvd., Ste. 103, Beaverton OR 97005
800-275-4899 • 503-643-4899 • Fax: 503-643-6129 • www.cui.com

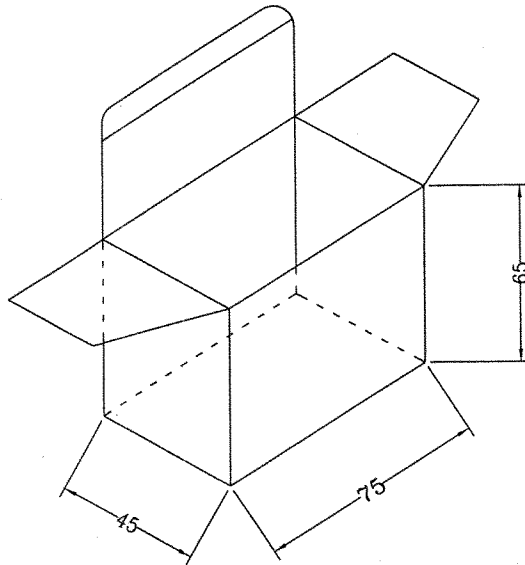

UNIT: mm